



S3-S/D01(02) Series



2W Unregulated Dual Separate output

Features

- 7 Pin SIL / 14 Pin DIL Package
- 1000 VDC Isolation
- Up to 3000 VDC Isolation
- Low Ripple and Noise
- Efficiency up to 80%
- -40 ~ 85°C Operation Temperature Range
- Non-Conductive Black Plastic Case

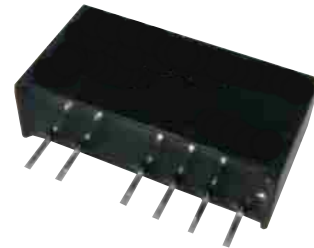

The S3 series is a family of cost effective 2W dual separate output DC-DC converters. These converters achieve low cost and ultra-miniature SIP 7 pin or DIP 14 pin size. Devices are encapsulated using flame retardant resin. The models operate from input voltage of 5, 12, 24 Vdc with output voltage of 3.3, 5, 7.2, 9, 12, 15, 18, 24 Vdc. High performance features include 1000Vdc~3000Vdc input/output isolation, high efficiency operation and output voltage accuracy of $\pm 3\%$ maximum. Standard features include an input range of $\pm 10\%$ tolerance and low output noise and ripple.

All specifications typical at $T_a=25^\circ\text{C}$, nominal input voltage and full load unless otherwise specified

OUTPUT SPECIFICATIONS		PHYSICAL SPECIFICATIONS	
Voltage accuracy	$\pm 3\%$	Case Material	Non-conductive Black Plastic (UL94V-0 rated)
Line regulation	$\pm 1.2\%$ / Per 1% V_{in} Change	Pin Material	0.5mm Alloy42 Solder-coated
Load regulation	(From 20% to 100% Load) $\pm 10\%$ (Output 3.3V Model) $\pm 20\%$	Potting Material	Epoxy (UL94V-0 rated)
Ripple & noise (20 MHz bandwidth)(1)	75mV pk-pk	Weight	2.7g
Temperature coefficient	$\pm 0.02\%/^\circ\text{C}$	Dimensions	SIP Case 0.76"x0.28"x0.39" DIP Case 0.80"x0.40"x0.27"
Capacitor load(2)	See table		
INPUT SPECIFICATIONS		ENVIRONMENT SPECIFICATIONS	
Voltage Range	$\pm 10\%$	Operating Temperature	$-40^\circ\text{C} \sim 85^\circ\text{C}$ (See Derating Curve)
Max. Input Current	See table	Maximum Case Temperature	100°C
No-Load Input Current	See table	Storage Temperature	$-40^\circ\text{C} \sim 125^\circ\text{C}$
Input Filter	Capacitors	Cooling	Nature Convection
Input Reflected Ripple Current(3)	20mA pk-pk		
ABSOLUTE MAXIMUM RATINGS(4)		GENERAL SPECIFICATIONS	
These are stress ratings. Exposure of devices to any of these conditions may adversely affect long-term reliability.		Efficiency	See table
Input Surge Voltage(100mS)	7 Vdc ,max.	I/O Isolation Voltage(3 sec)	
5 Models	15 Vdc ,max.	Input/Output1&Output2	1000~3000Vdc
12 Models	28 Vdc ,max.	Output1/Output2	1000Vdc
24 Models	260°C ,max.	I/O Isolation Capacitance	60 pF Typ.
Soldering Temperature		I/O Isolation Resistance	1000M Ohm
(1.5mm from case 10sec. max.)		Switching Frequency	Variable 80kHz
		Humidity	95% rel H
		Reliability Calculated MTBF(MIL-HDBK-217 F)	>1,121 Mhrs
		Safety Standard : (designed to meet)	IEC 60950-1

S3 - 2W Unregulated Dual Separate output

PARTNUMBER STRUCTURE			
S3	- 12 05	D 0 1	H
Series Name	Input Voltage	Case Type	3KVdc Isolation
	05 - 5V 12 - 12V 24 - 24V	S - SIP Case D - DIP Case	Optional, if no suffix "H" mean 1 KVdc Isolation
	Dual Separate Output Voltage (1W)		
	3R3S/D01 - 5V,3.3V	3R3S/D02 - 3.3V,3.3V	
		05S/D02 - 5V,5V	
	7R2S/D01 - 5V,7.2V	7R2S/D02 - 7.2V,7.2V	
	09S/D01 - 5V,9V	09S/D02 - 9V,9V	
	12S/D01 - 5V,12V	12S/D02 - 12V,12V	
	15S/D01 - 5V,15V	15S/D02 - 15V,15V	
	18S/D01 - 5V,18V	18S/D02 - 18V,18V	
	24S/D01 - 5V,24V	24S/D02 - 24V,24V	

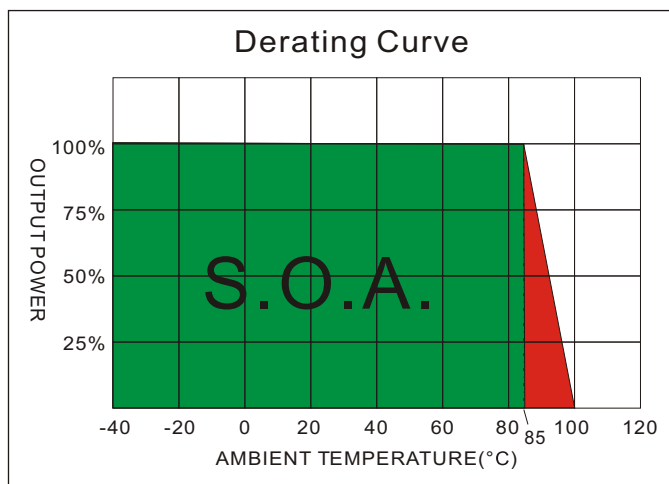

MODEL SELECTION GUIDE

MODEL NUMBER	INPUT Voltage Range (Vdc)	INPUT Current		OUTPUT Voltage(Vdc) Output1 Output2	OUTPUT Current Full load(mA) Output1 Output2		EFFICIENCY @FL(%)	Capacitor Load(uF)
		No-Load (mA)	Full Load (mA)		Output1	Output2		
S3-053 R3S/D01	5	35	519	5, 3.3	200, 303	77	220	
S3-057 R2S/D01	5	35	519	5, 7.2	200, 139	77	220	
S3-05 09S/D01	5	35	519	5, 9	200, 111	77	220	
S3-05 12S/D01	5	35	500	5, 12	200, 83	80	220	
S3-05 15S/D01	5	35	500	5, 15	200, 67	80	220	
S3-05 18S/D01	5	35	519	5, 18	200, 55	77	220	
S3-05 24S/D01	5	35	519	5, 24	200, 41	77	220	
S3-123 R3S/D01	12	25	216	5, 3.3	200, 303	77	220	
S3-127 R2S/D01	12	25	216	5, 7.2	200, 139	77	220	
S3-12 09S/D01	12	25	216	5, 9	200, 111	77	220	
S3-12 12S/D01	12	25	208	5, 12	200, 83	80	220	
S3-12 15S/D01	12	25	208	5, 15	200, 67	80	220	
S3-12 18S/D01	12	25	216	5, 18	200, 55	77	220	
S3-12 24S/D01	12	25	216	5, 24	200, 41	77	220	
S3-243 R3S/D01	24	12	108	5, 3.3	200, 303	77	220	
S3-247 R2S/D01	24	12	108	5, 7.2	200, 139	77	220	
S3-24 09S/D01	24	12	108	5, 9	200, 111	77	220	
S3-24 12SD/01	24	12	104	5, 12	200, 83	80	220	
S3-24 15S/D01	24	12	104	5, 15	200, 67	80	220	
S3-24 18S/D01	24	12	106	5, 18	200, 55	78	220	
S3-24 24S/D01	24	12	108	5, 24	200, 41	77	220	

Suffix "H" means 3 KVdc isolation

S3 - 2W Unregulated Dual Separate output

MODEL NUMBER	INPUT Voltage Range (Vdc)	INPUT Current		OUTPUT Voltage(Vdc) Output1 Output2	OUTPUT Current		EFFICIENCY @FL(%)	Capacitor Load(uF)
		No-Load (mA)	Full Load (mA)		Full load(mA) Output1 Output2			
S3-053 R3S/D02	5	35	519	3.3 , 3.3	303 , 303	77	220	
S3-05 05S/D02	5	35	512	5 , 5	200 , 200	78	220	
S3-057 R2S/D02	5	35	512	7.2 , 7.2	139 , 139	78	220	
S3-05 09S/D02	5	35	512	9 , 9	111 , 111	78	220	
S3-05 12S/D02	5	35	512	12 , 12	83 , 83	78	220	
S3-05 15S/D02	5	35	506	15 , 15	67 , 67	79	220	
S3-05 18S/D02	5	35	500	18 , 18	55 , 55	80	220	
S3-05 24S/D02	5	35	500	24 , 24	41 , 41	80	220	
S3-123 R3S/D02	12	25	216	3.3 , 3.3	303 , 303	77	220	
S3-12 05S/D02	12	25	216	5 , 5	200 , 200	77	220	
S3-127 R2S/D02	12	25	216	7.2 , 7.2	139 , 139	77	220	
S3-12 09S/D02	12	25	216	9 , 9	111 , 111	77	220	
S3-12 12S/D02	12	25	213	12 , 12	83 , 83	78	220	
S3-12 15S/D02	12	25	213	15 , 15	67 , 67	78	220	
S3-12 18S/D02	12	25	208	18 , 18	55 , 55	80	220	
S3-12 24S/D02	12	25	208	24 , 24	41 , 41	80	220	
S3-243 R3S/D02	24	12	106	3.3 , 3.3	303 , 303	78	220	
S3-24 05S/D02	24	12	106	5 , 5	200 , 200	78	220	
S3-247 R2S/D02	24	12	106	7.2 , 7.2	139 , 139	78	220	
S3-24 09S/D02	24	12	106	9 , 9	111 , 111	78	220	
S3-24 12SD/02	24	12	104	12 , 12	83 , 83	80	220	
S3-24 15S/D02	24	12	104	15 , 15	67 , 67	80	220	
S3-24 18S/D02	24	12	104	18 , 18	55 , 55	80	220	
S3-24 24S/D02	24	12	104	24 , 24	41 , 41	80	220	

Suffix "H" means 3 KVdcisolation

NOTE

1. Ripple/Noise measured with 20MHz bandwidth.
2. Tested by minimal Vin and constant resistive load.
3. Measured Input reflected ripple current with a simulated source inductance of 12uH.
4. Exceeding the absolute ratings of the unit could cause damage. It is not allowed for continuous operating.
5. Operation under no-load conditions will not damage these devices, however they may not meet all listed specifications.

S3 - 2W Unregulated Dual Separate output

MECHANICAL SPECIFICATIONS

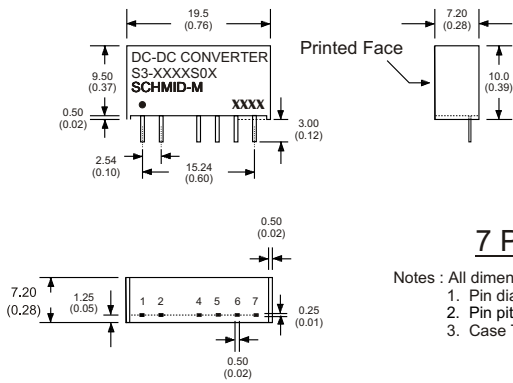

7 Pin SIL Package

- Notes : All dimensions are typical in millimeters (inches).
1. Pin diameter: 0.5 ± 0.05 (0.02 ± 0.002)
 2. Pin pitch and length tolerance: ± 0.35 (± 0.014)
 3. Case Tolerance: ± 0.5 (± 0.02)

PIN CONNECTIONS	
PIN NUMBER	Dual Separate
1	+V Input
2	-V Input
4	+V1 Output
5	-V1 Output
6	+V2 Output
7	-V2 Output

(The Pin Connection of high isolation one is the same with normal one.)

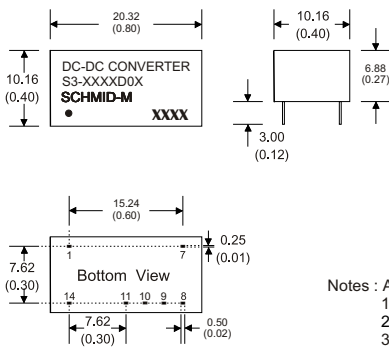

14 Pin DIL Package

- Notes : All dimensions are typical in millimeters (inches).
1. Pin diameter: 0.5 ± 0.05 (0.02 ± 0.002)
 2. Pin pitch and length tolerance: ± 0.35 (± 0.014)
 3. Case Tolerance: ± 0.5 (± 0.02)

PIN CONNECTIONS	
PIN NUMBER	Dual Separate
1	-V Input
7	N.C
8	-V2 Output
9	+V2 Output
10	-V1 Output
11	+V1 Output
14	+V Input

(The Pin Connection of high isolation one is the same with normal one.)