

## SRAHS300-110A24 DC-DC Converter

Input 66V-160V, Output 24V/12.5A, Industry Standard half Brick

### Contents

Features .....	1
Ordering Information .....	1
Outline Diagram .....	2
Specifications .....	2
Characteristic Curves .....	4
Design Considerations .....	6
Basic Connection .....	6
Recommended Layout .....	6
Input Voltage Range .....	6
External Capacitance .....	6
Remote Control .....	7
Output Voltage Adjust .....	7
Remote Sense .....	8
Output Over Voltage Protection(OVP) .....	8
EMC Solution .....	8
Thermal Consideration .....	8
Safety Consideration .....	9
Product Installation and Heat Dissipation .....	9
ESD Control .....	9
Cleaning Notice .....	9
Delivery Package Information .....	9
Quality Statementc .....	9
Contact Information .....	9



### Features

- ◆ Half-Brick (62.0mm×58.9mm×12.7mm)
- ◆ Input Under Voltage Protection (40V to 65V Turn off)
- ◆ Positive Logic Control (3.5V to 15V Turn on)
- ◆ Output Over Voltage Protection
- ◆ Output Voltage Adjust Range: ±10 % of the rated output voltage
- ◆ Output Short-circuit Protection, auto-recovery
- ◆ 3000Vac Isolation Voltage
- ◆ Operating Ambient Temperature: -40°C to +85°C
- ◆ Over Temperature Protection: 110°C Typ.
- ◆ Meets requirements of Standard EN50155
- ◆ Application: Industry ,Railway & Rail transit

### Ordering Information

See Contents for individual product ordering numbers.

Suffix	Meaning	Ordering Model
--	Basic Model	SRAHS300-110A24
P	Negative Logic Control. Turn off when CNT pin is applied to 3.5~15V voltage or kept floating; Turn on when CNT pin is applied to 0~1.5V voltage	SRAHS300-110A24P

## SRAHS300-110A24 DC-DC Converter

Input 66V-160V, Output 24V/12.5A, Industry Standard half Brick

### Outline Diagram

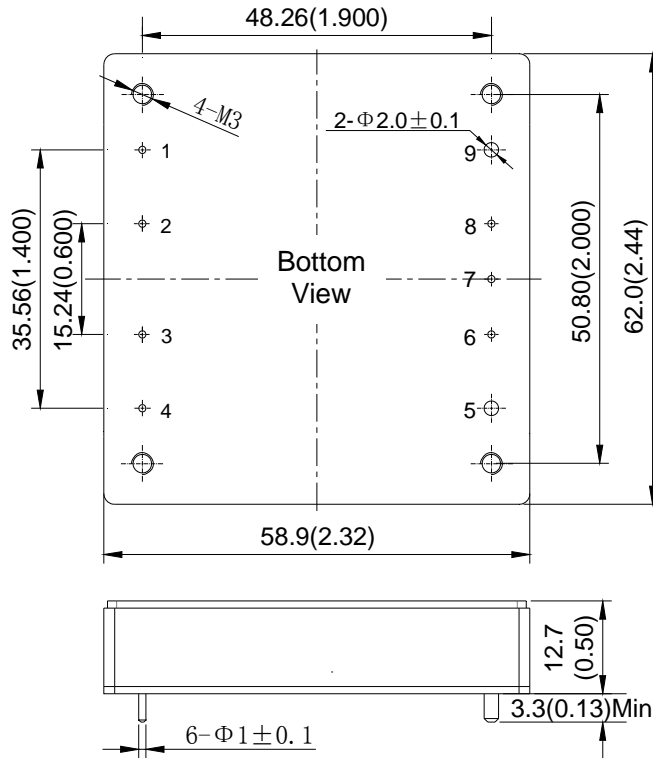

Pin	Symbol	Function
1	-Vin	Negative Input
2	NP	No Pin
3	CNT	Remote Control Pin
4	+Vin	Positive Input
5	+Vo	Positive output
6	+S	Positive Remote Sense
7	TRIM	Output voltage adjust
8	-S	Negative Remote Sense
9	-Vo	Negative Output

Case material: Black flame retardant Plastic;  
Pins: copper with gold plating Aluminum baseplate can be connected to Protective Earth pin by M3 screw.

Notes: all dimensions in mm(inches)

Tolerances: X.X±0.5mm(X.XX±0.02)

X.XX±0.25mm(X.XXX±0.010)

### Specifications

Unless otherwise specified, all values are given at room temperature and standard atmosphere pressure, pure resistive load and basic connection.

Input	Symbol	Min	Typ	Max	Unit	Conditions
Input Voltage	$V_{in}$	66	110	160	V	—
Maximum Input Current	$I_{in}$	—	—	5.3	A	—
Positive Logic Remote Control	Current	—	—	1.0	mA	CNT source current when low level turned off
	On	—	3.5	15.0	V	Refer to $-V_{in}$ ; Also turn on when CNT floating.
	Off	—	0	1.5	V	Refer to $-V_{in}$
Negative Logic Control	On	—	0	1.5	V	Refer to $-V_{in}$
	Current	—	—	5.0	mA	CNT source current when low level turned on
	Off	—	3.5	15.0	V	Refer to $-V_{in}$ ; Turn off when CNT floating
	Current	—	—	5.0	mA	CNT sink current when high level turned off.
Under Voltage Threshold	$V_{UVLO}$	40	—	65	V	—

Output	Symbol	Min	Typ	Max	Unit	Conditions
Output Power	$P_o$	—	—	300	W	—
Output Voltage	$V_o$	23.76	24.00	24.24	V	—

## SRAHS300-110A24 DC-DC Converter

Input 66V-160V, Output 24V/12.5A, Industry Standard half Brick

Continue

Output	Symbol	Min	Typ	Max	Unit	Conditions	
Output Current	$I_o$	—	12.5	—	A	—	
Output Voltage Adjust Range	$V_{trim}$	21.6	—	26.4	V	trim up: $P_o \leq 300W$ trim down: $I_o \leq 12.5A$	
Remote Sense Compensation Range	$V_{sense}$	—	—	0.5	V	—	
Line Regulation	$S_V$	—	—	$\pm 0.2$	% $V_o$	$V_{in}: 66V \sim 160V, I_o = 12.5A$	
Load Regulation	$S_I$	—	—	$\pm 0.5$	% $V_o$	$V_{in} = 110V, I_o: 0\% \sim 100\% I_{o,nom}$	
Peak to Peak Ripple and Noise	$\Delta V_{pp}$	—	—	200	mV	20MHz bandwidth, Output external capacitance value is shown in the "Basic Connection"	
Load Transient	Recovery Time	$t_{tr}$	—	—	400	$\mu s$	Load change: 25%~50%~25% & 50%~75%~50%; Current change: 0.1A/ $\mu s$
	Voltage Deviation	$\Delta V_{tr}$	—	—	$\pm 960$	mV	
Capacitive Load Range	$C_o$	0	—	2000	$\mu F$	$V_{in}: 66V \sim 160V$ , pure resistive load	
Output Overshoot	$V_{IO}$	0	—	10	% $V_o$		
OVP Set Point	$V_{ov,set}$	28.8	—	33.6	V	—	
Current Limit Inception	$I_{o,lim}$	13.8	—	22.5	A	—	
Output Short-circuit Protection	hiccup mode, automatic recovery						

General	Symbol	Min	Typ	Max	Unit	Conditions
Efficiency	$\eta$	—	89	—	%	$V_{in} = 110V, I_o = 12.5A$
Switching Frequency	$f_s$	—	290	—	kHz	—
Isolation Resistance	$R_{iso}$	50	—	—	M $\Omega$	Under normal atmospheric pressure, Relative humidity: 90%, Test voltage: 500Vdc
Isolation Voltage	$V_{iso}$	3000	—	—	Vac	Input to output, Leak Current $\leq 5mA$
		2000	—	—	Vac	Input to case, Leak Current $\leq 5mA$
		2000	—	—	Vac	Output to case, Leak Current $\leq 5mA$
Thermal resistance	$R_{\theta CA}$	—	8.53	—	$^{\circ}C/W$	Natural Convection Without Heatsink
	$R_{\theta CA}$	—	3.74	—	$^{\circ}C/W$	Natural Convection With Heatsink
	$R_{\theta CA}$	—	6.95	—	$^{\circ}C/W$	100LFM Convection Without Heatsink
	$R_{\theta CA}$	—	2.78	—	$^{\circ}C/W$	100LFM Convection With Heatsink
	$R_{\theta CA}$	—	5.57	—	$^{\circ}C/W$	200LFM Convection Without Heatsink
	$R_{\theta CA}$	—	1.81	—	$^{\circ}C/W$	200LFM Convection With Heatsink
	$R_{\theta CA}$	—	4.55	—	$^{\circ}C/W$	300LFM Convection Without Heatsink
	$R_{\theta CA}$	—	1.48	—	$^{\circ}C/W$	300LFM Convection With Heatsink
	$R_{\theta CA}$	—	4.06	—	$^{\circ}C/W$	400LFM Convection Without Heatsink
	$R_{\theta CA}$	—	1.17	—	$^{\circ}C/W$	400LFM Convection With Heatsink

## SRAHS300-110A24 DC-DC Converter

Input 66V-160V, Output 24V/12.5A, Industry Standard half Brick

Continue

General	Symbol	Min	Typ	Max	Unit	Conditions
Operating Baseplate Temperature	—	-40	—	100	°C	—
Operating Ambient Temperature	—	-40	—	85	°C	See Natrual Cooling Derating
OTP Set Point	T <sub>ref</sub>	—	110	—	°C	Baseplate Temperature
Storage Temperature	—	-55	—	125	°C	—
Temperature Coefficient	S <sub>T</sub>	—	—	±0.02	%/°C	—
MTBF	—	—	2×10 <sup>6</sup>	—	h	BELLCORE TR-332
Shock and Vibration	Meets EN50155					
Hand Soldering	Maximum soldering Temperature < 425°C, and duration < 5s					
Wave Soldering	Maximum soldering Temperature < 255°C, and duration < 10s					
Weight	—	—	98	—	g	—

EMC SPECIFICATIONS	Conditions	Level
EMI Conducted emission	EN55032	CLASS A(See Page 8)
Surge immunity	IEC/EN61000-4-5 line to line(±1kV/2Ω); GB/T 17626.5 line to ground(±2kV/12Ω)	Perf. Criteria B(See Page 8)
Fast transient/burst immunity	IEC/EN61000-4-4 ±2kV(5/50ns, 5kHz) GB/T 17626.4	Perf. CriteriaA(See Page 8)

### Characteristic Curves

Load Transient Response

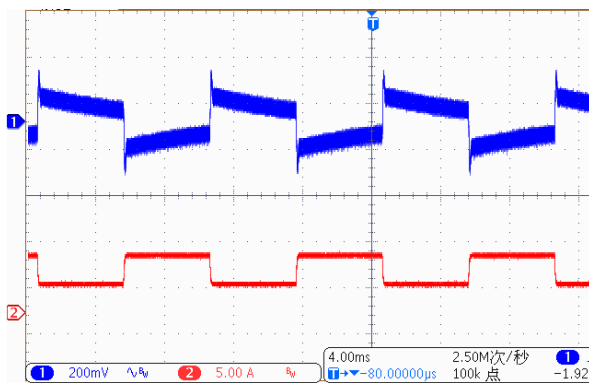

Load change:25%~50%  
~25% I<sub>o,nom</sub>, 0.1A/μs  
Vin=110Vdc

Trace1: 200mV/div  
Trace2: 5A/div  
Time scale: 4ms/div

Load Transient Response

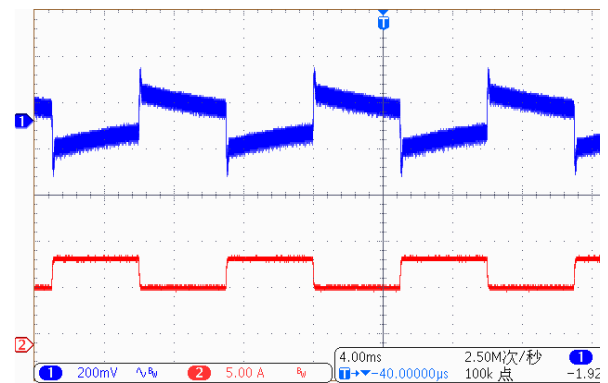

Load change:50~75%  
~50% I<sub>o,nom</sub>, 0.1A/μs  
Vin=110Vdc

Trace1: 200mV/div  
Trace2: 5A/div  
Time scale: 4ms/div

## SRAHS300-110A24 DC-DC Converter

Input 66V-160V, Output 24V/12.5A, Industry Standard half Brick

Output Ripple and noise

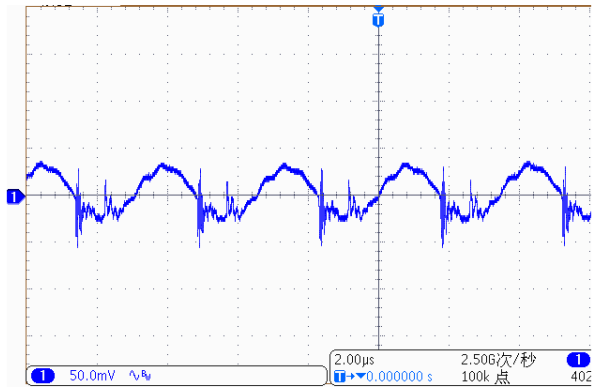

$V_{in}=110Vdc, I_o=12.5A$  (20MHz)

Rise Time

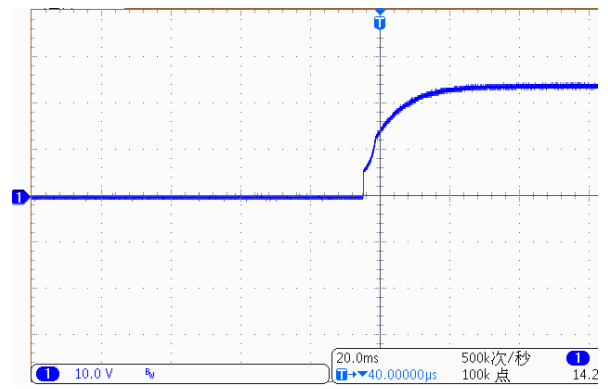

$V_{in}=110Vdc, I_o=12.5A$  (20MHz)

Start-up Delay Time

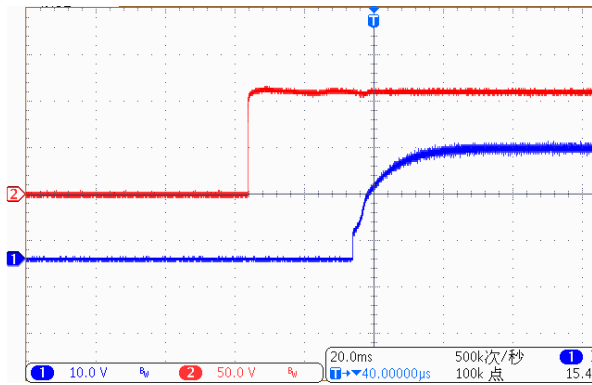

$V_{in}=110Vdc, I_o=12.5A$  (20MHz)

Efficiency vs Current

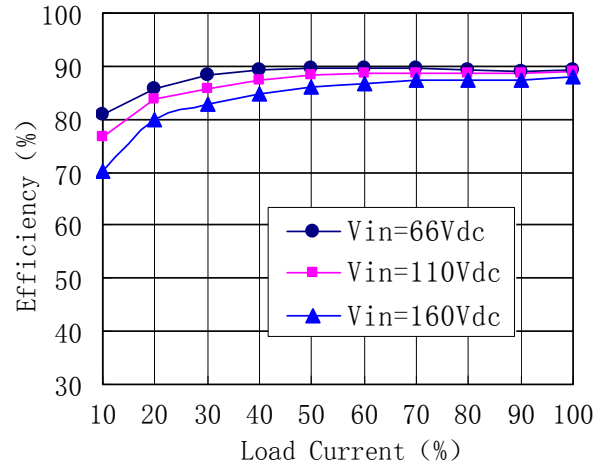

Derating curve with 0.95"HS radiator

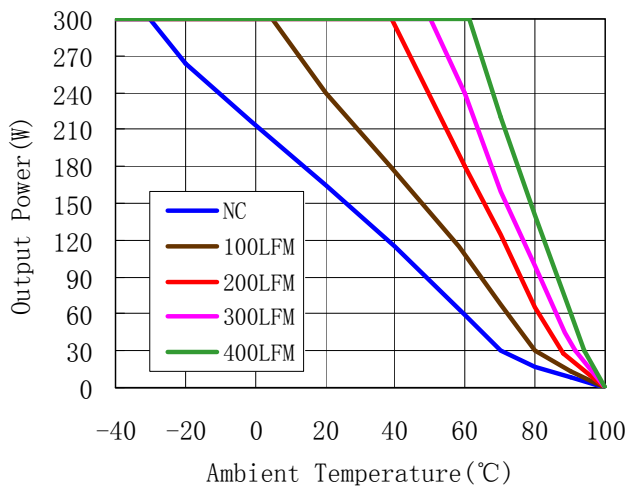

## SRAHS300-110A24 DC-DC Converter

Input 66V-160V, Output 24V/12.5A, Industry Standard half Brick

### Design Considerations

#### Basic Connection

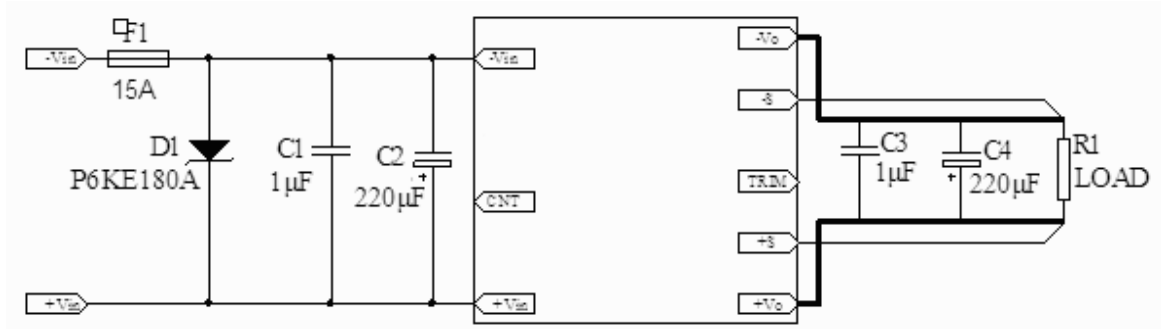

Notes: The basic connection indicates the basic requirements. Please refer to the instruction followed for further information.

#### Recommended Layout

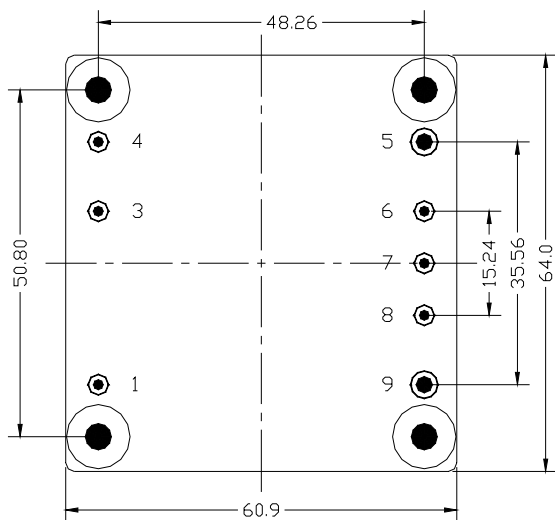

NO.	Recommendation & Notes
Pad Design	5 and 9 Pad holes: 2.5mm, pad diameter including hole:5.0mm; others Pad holes: 1.5mm, pad diameter including hole:3.0mm; the fixed holes at the four corners are metallized, with diameter of 4.1mm and pad diameter including hole of 8.5mm is keep out layer. The product can be fixed on the user board by M3 screws
Safety	Isolated Converters, care to the spacing between input and output, input and protective ground, output and protective ground.
Electrical	The Vin(-) and Vo(-) planes should be placed under of the converter separately. Avoid routing sensitive signal or high disturbance AC signal under the converter.

#### Input Voltage Range

The input voltage range of the DC/DC converter is 66V~160V. The input impedance of the converter looks like a negative resistor, which can interact with the reactance of the power bus (including any filter elements that have been added to the input of the converter), causes an unstable condition.

The method to determine whether the impedance of the power bus too high or not is to decrease the converter's input voltage from higher to lower gradually, if the output voltage decreases (unstable sometime) with the lower input voltage, it will be considered the impedance too large. For further confirmation, one electrolytic capacitor can be paralleled to the converter pins after the converter shuts down (one 1µF ceramic capacitor may be required to be paralleled with the electrolytic capacitor), if the output getting better, it will be sure that the impedance is too large.

#### External Capacitance

Unless special purpose (i.e. prolonging hold-up time, input impedance matching), the recommended input filter's capacitance ranges 47µF~220µF, which not only offers a stable system, and reduces the cost, but also lessens the inrush current when the power supplies.

When larger capacitance is required, a circuit of suppressing the inrush current is recommended when the regulator start-up and a discharge circuit is recommended when the output dropped, ensuring the reliability and safety of other equipments in the system.

## SRAHS300-110A24 DC-DC Converter

Input 66V-160V, Output 24V/12.5A, Industry Standard half Brick

### Remote Control

Remote control can be offered by setting right control voltage level (floating, high resistance) to CNT pin. SRAHS300-110A24 is provided with positive logic remote control. The circuit diagram is shown as "Internal Circuit Diagram for Positive Logic Control". When the pin is left floating or the voltage of the pin is higher than 3.5V~15V, the converter will turn on. When the level is less than 1.5V, the converter will turn off. SRAHS300-110A24P is provided with negative logic remote control. It has the same characteristic as SRAHS300-110A24, except control logic. When the pin is left floating or the voltage of the pin is 3.5V~15V, the converter will turn off. When the level is less than 1.5V, the converter will turn on.

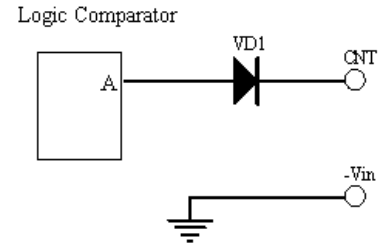

**Internal Circuit Diagram For Positive Logic Control**

Due to the logic comparator is semiconductor integrated chip, they have low endurance to surge. Care should be taken to prevent CNT from surge, A TVS should be used in some cases.

In some applications, extra controls will be designed for the converter in user's PCB, such as output short circuit protection, over voltage protection, under voltage protection, synchronous control to the converter output voltage, and so on, remote control will give you help. The controls can be achieved by external circuit applied to the CNT pin.

This product is Positive logic control, when signal exceed the range of 3.5V~15V, or the level which can be received has a very narrow range, (such as turn-on between 5.0V~5.5V), the aux. circuit will be required. Please contact us for more information.

### Output Voltage Adjust

The converters have an Output Voltage adjust pin (Trim). This pin can be used to adjust the output voltage above or below Output voltage initial setting. The maximum value of the trimmed up is 10%, even  $\pm S$  pins are used to compensate the voltage simultaneously, the sum of the trimmed up and the compensation should not be more than 10%, or the characteristics will not be assured in compliant with the specification, even the over voltage protection may be triggered. The output power can not exceed 300W at increased output voltages, and the output current can not exceed 12.5A.

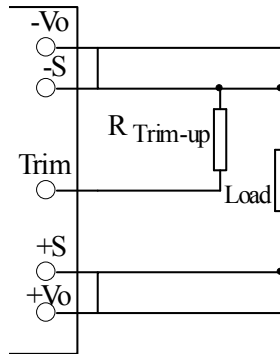

**Connection for Trimming Up**

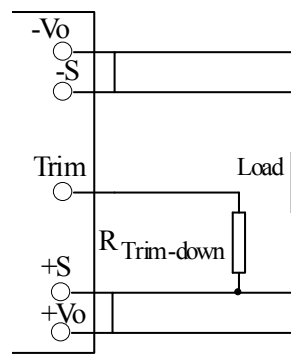

**Connection of Trimming Down**

External circuit is connected as the figure shown, the resistance is calculated as the formula below, please note that the formula will be invalid when  $R_{Trim-up}$ ,  $R_{Trim-down}$  are used simultaneously, users adjust the value based on the resistance applied.

$$\text{Resistance for trimming up : } R_{Trim-up} = \left( \frac{53.75}{\Delta V} - 18 \right) (k\Omega)$$

$$\text{Resistance for trimming down: } R_{Trim-down} = \left( \frac{(21.5V_0 - 18\Delta V - 53.75)}{\Delta V} \right) (k\Omega)$$

$V_0$ : rated output voltage;

$\Delta V$ : change rate, divide output voltage by rated output voltage;

$R_{Trim-up}$ ,  $R_{Trim-down}$ : resistance for trimming up or down, Unit: k $\Omega$ .

## SRAHS300-110A24 DC-DC Converter

Input 66V-160V, Output 24V/12.5A, Industry Standard half Brick

### Remote Sense

The remote sense can be used to compensate for the voltage drop between the output pins of the converter and the load input pins by +S and -S pins. The +S and -S pins should be connected to the input pins of the load respectively. The remote sense circuit will compensate for up to 0.5V drop between the sense voltage and the voltage at the output pins. If the remote sense is not needed, the -S should be connected to -Vo and +S should be connected to +Vo.

The anti-interference design should be considered when the +S and -S pins are connected to the pins to be compensated. The +S and -S traces should be located close to a ground trace or ground plane, and the area they surrounded should be minimized (just for electrical isolation); If cable connection presents, twisted pair wires should be used, EMI core are equipped with the twisted pair wires to reduce common mode noise when necessary, the sense leads should not be longer than 200mm, or the system characteristics may not be assured. The sense leads only can carry very little current, and are not used for converter power output. Care should be taken in operation to avoid damaging the converter.

### Output Over Voltage Protection(OVP)

The clamp type over voltage protection feature is used to protect the converter, when output voltage exceeds 120%~140%of the rated output voltage ( the set point is between 28.8V~33.6V, there is the difference based on the specific parameters, but not beyond the range), the output voltage will be clamped. Be advised that to shut down the converter by using remote control (CNT) if it can not be repaired timely. Avoid the continuous resetting of the unit because that will damage the converter.

### EMC Solution

Recommendation circuit for EMI Conducted emission、Fast transient/burst immunity、Surge immunity.

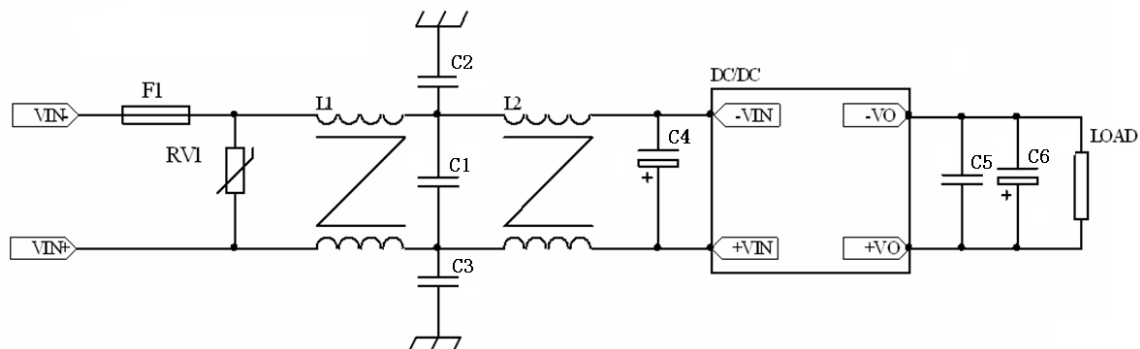

Part No.	Components	Part No.	Components
F1	15A Fuse	L1	1.6mH Common Mode Inductor
RV1	221KD14 Varistor	L2	2.2mH Common Mode Inductor
C1	1μF Film Capacitor	C5	0.1μF Ceramic Capacitor
C2、C3	1000pF Y-CAP	C4、C6	220μF E-CAP

### Thermal Consideration

The loss of the converters in normal operation will be converted into heat which can cause the converters itself to rise in temperature. SRAHS300-110A24 is provided with Over Temperature Protection Feature. The temperature sensor is located on the aluminum baseplate. The converters will be off when the average temperature of the baseplate is higher than that of the over temperature protection point.

In order to ensure that the converter can work normally at rated power, the client system needs to ensure that the aluminum baseplate temperature is less than 100°C. When aluminum baseplate temperature is higher than 100°C, the derating curves should be referred or external heat dissipation measures. Forced air cooling or heatsink should be used. The air tunnel should be considered for forced air cooling, to avoid heated air be hindered or forming swirl; when heatsink used, it should be attached the converter closely, through double-side thermal conductivity insulation adhesive or thermal conductivity silicone for heat exchange. It is necessary to select the appropriate radiator according to the heat resistance of the radiator without air cooling.

## **SRAHS300-110A24 DC-DC Converter**

Input 66V-160V, Output 24V/12.5A, Industry Standard half Brick

---

### **Safety Consideration**

The converter, as one component for the end user, should be installed into the equipment, and all the safety considerations are achieved under certain condition. It is required to meet safety requirements in system design for the user.

To avoid fire and be protected when short circuit occurred, it is recommended that a fast blow fuse with rating 2.5~3 times of converter continuous input peak current is used in series at the input terminal.(Inrush current suppression circuit is required for greater filter capacitance at input terminal, or it will result in the misoperation of the fuse).

### **Product Installation and Heat Dissipation**

The product can be installed in user board, suggest using M3 screw to fix the products in user board, in order to enhance the bearing ability when impact and vibration coming. Note that, when you hammer the product using screws, this product shall be first fixed, again a needle pin welding, prevent strain soldered dot. Moreover the biggest torque of fastening screw cannot exceed 0.6 N.m, otherwise it will likely damage. the structural related to studs.

Metal surface of this product structured by aluminum PCB which has good thermal conductivity, mapping the overburden with heat conduction medias or thermal gaskets, then install proper radiator.

Proper radiator and flows through radiator wind will greatly enhance products cooling capacity. When you install radiator, you should be paid attention to the length of the bolt, ensure that has no relevant relatives with the screws fixed on PCB.

### **ESD Control**

The converters are processed and manufactured in an ESD controlled environment and supplied in conductive packaging to prevent ESD damage from occurring before or during shipping. It is essential that they are unpacked and handled using an ESD control procedures. Failure to do so affects the lifetime of the converter.

### **Cleaning Notice**

The converter is suitable for water washing, because it does not have any pockets where water could be trapped long-term. Users should ensure that the drying process is adequate and of sufficient duration to remove all water from the converter after washing, do not power up the unit until it is completely dry.

### **Delivery Package Information**

Package material is multiple wall corrugated ,internal material is anti-static foam ,it's surface resistance is from  $10^5 \Omega$  to  $10^{12} \Omega$ . Tray capacity: 12 PCS/box ,Tray weight: 1.18kg; Carton capacity:15×12=180 PCS ,Carton weight:17.7kg.

### **Quality Statement**

The converters are manufactured in accordance with ISO-9001 system requirements, in compliant with EN50155, and are monitored 100% by auto-testing system, 100% burn in.

The warranty for the converters is 5-year.