

Product Feature

- ◆ Package Type: 1"X 1"
- ◆ Input voltage range: 4:1
- ◆ Operating temperature range: -40°C - +105°C
- ◆ Isolation voltage: 1500VDC
- ◆ High efficiency: 90% (Typ.)
- ◆ The mechanism has input undervoltage protection,
- ◆ Output short circuit protection and over current protection
- ◆ Fields of application: Power, industrial control, communications, Internet of Things, automotive, etc



Selection Guide

Part No.	Input Voltage (VDC)		Output		Full Load Efficiency% (Typ.)	Capacitive Load(μF) Max.
	Nominal (Range)	Max.	Voltage (VDC)	Current (mA)Max.		
SURB 2403 YMD-30WR4	24 (9-36)	40	3.3	6000	84	10000
SURB 2405 YMD-30WR4	24 (9-36)	40	5	6000	88	10000
SURB 2406 YMD-30WR4	24 (9-36)	40	6	5000	88	7200
SURB 2412 YMD-30WR4	24 (9-36)	40	12	2500	90	1500
SURB 2415 YMD-30WR4	24 (9-36)	40	15	2000	90	1000
SURB 2424 YMD-30WR4	24 (9-36)	40	24	1250	90	750
SURA 2412 YMD-30WR4	24 (9-36)	40	±12	±1250	86	#680
SURA 2415 YMD-30WR4	24 (9-36)	40	±15	±1000	86	#470
SURA 2424 YMD-30WR4	24 (9-36)	40	±24	±625	86	#330
SURB 4803 YMD-30WR4	48 (18-75)	80	3.3	6000	83	7200
SURB 4805 YMD-30WR4	48 (18-75)	80	5	6000	88	7200
SURB 4812 YMD-30WR4	48 (18-75)	80	12	2500	88	2000
SURB 4815 YMD-30WR4	48 (18-75)	80	15	2000	88	1500
SURB 4824 YMD-30WR4	48 (18-75)	80	24	1250	88	470

Note:

1. Suffix plus "H" means plus heat sink package, plus "A2S" for extended wiring package, suffix plus "A4S" for extended rail type package;
2. The input end of the extended package is equipped with anti-reverse protection function, and its full load efficiency will be reduced by 2%;
3. The maximum capacitive load "#" means that the positive and negative outputs are connected to the same capacitance.

#Each output

Input Specifications

Item	Operating Conditions	Min.	Typ.	Max.	Unit	
Input Current(full load/no-load)	24VDC nominal input series	3.3VDC Output	--	982/6	1032/20	mA
		5VDC Output	--	1420/4	1453/12	
		Other Output	--	1388/4	1420/12	
	48VDC nominal input series	3.3VDC Output	--	497/10	520/20	
		Other Output	--	710/8	735/15	
Reflected Ripple Current	24VDC nominal input series	--	100	--	mA	
	48VDC nominal input series	--	40	--		
Impulse Voltage	24VDC nominal input series	-0.7	--	50	VDC	
	48VDC nominal input series	-0.7	--	100		
Starting Voltage	24VDC nominal input series	--	--	9	VDC	
	48VDC nominal input series	--	--	18		
Input UnderVoltage Protection	24VDC nominal input series	5.5	7.5	--	VDC	
	48VDC nominal input series	12.0	15.5	--		
Starting Time	24VDC Nominal input and constant resistance load	--	30	100	ms	
	48VDC Nominal input and constant resistance load	--	10	--		
Ctrl	turn off module	Connected GND or (0-1.2VDC)				
	turn on module	No connected or (3.5-12VDC)				
	Input current when off	--	2	7	mA	
Input Filter		PI filter				
Hot Plug		Unavailable				

Output Specifications

Item	Operating Conditions	Min.	Typ.	Max.	Unit
Output Voltage Accuracy	5%-100% load	--	±1.0	±3.0	%
Linear Regulation	Vin=Min. to Max. @Full Load	--	±0.2	±0.5	%
Load Regulation	5%-100% load	--	±0.5	±1.0	%
Ripple & Noise	20MHz bandwidth,5%-100% load	--	100	200	mVp-p
Transient Recovery Time	25% Load Step Change,nominal input voltage	--	250	500	µs
Transient Response Deviation	25% Load Step Change,nominal input voltage	--	±3	±8	%
Temperature Coefficient	Full Load	--	--	±0.03	%/°C
Trim	Input voltage range	90	--	110	%Vo
Over Current Protection	Input voltage range	110	170	260	%Io
Short-Circuit Protection	Input voltage range	Continuous, Self-Recovery			

General Specifications

Item	Operating Conditions	Min.	Typ.	Max.	Unit
Isolation Voltage	I-O, test time 1 minute, leakage current less than 1mA	1500	--	--	VDC
Insulation Resistance	Input-output, insulated voltage 500VDC	1000	--	--	MΩ
Isolation Capacitance	Input-output, 100KHz/0.1V	--	2000	--	pF
Operating Temperature	See Fig 1	-40	--	+105	°C
Storage Temperature		-55	--	+125	°C
Storage Humidity	Non-condensing	5	--	95	%RH
Soldering Profile	1.5mm from case for 10 sec	--	--	+300	°C
Switching Frequency	PWM	--	400	--	kHz
MTBF	MIL-HDBK-217F@25°C	1000	--	--	K Hours

Mechanical Specifications

Case Material	Aluminum alloy
Package Dimensions	25.40 X 25.40 X 12.00 mm
Weight	21.00g(Typ.)
Cooling Method	Free air convection

EMC Specifications

EMI	CE	CISPR32/EN55032 CLASS B (Figure 4)
	RE	CISPR32/EN55032 CLASS B (Figure 4)
EMS	ESD	EN61000-4-2 Air ± 8kV , Contact ± 6kV perf. Criteria B
	RS	EN61000-4-3 10V/m perf. Criteria A
	EFT	EN61000-4-4 ±2kV perf. Criteria B
	Surge	EN61000-4-5 ±1kV perf. Criteria B
	CS	EN61000-4-6 3Vrms perf. Criteria A

Typical Characteristic Curves

Temperature Derating Curve (24V) Figure1

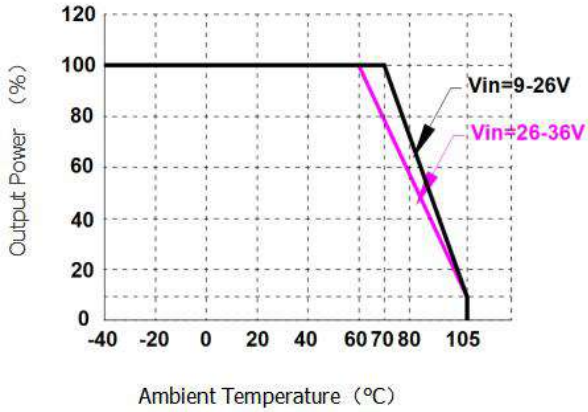

Temperature Derating Curve (48V) Figure2

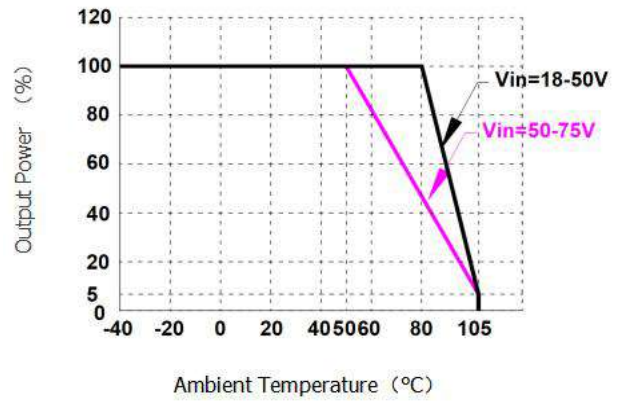

Efficiency Vs Input Voltage (Full Load)

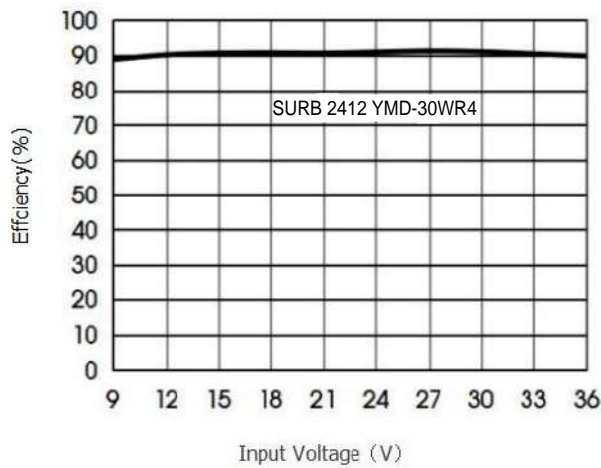

Efficiency Vs Output Load (Vin=24V)

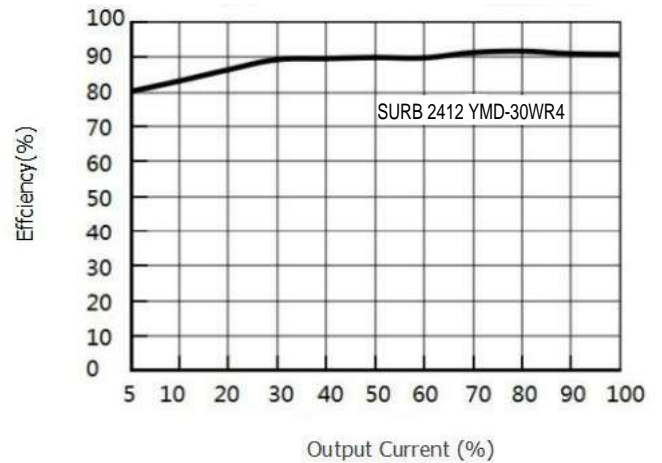

Efficiency Vs Input Voltage (Full Load)

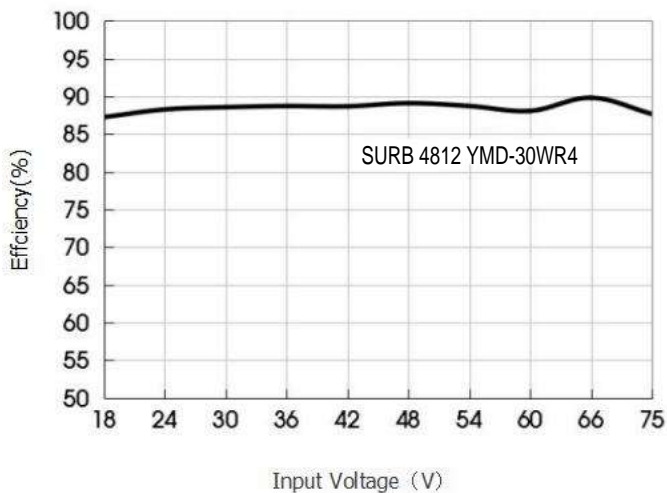

Efficiency Vs Output Load (Vin=48V)

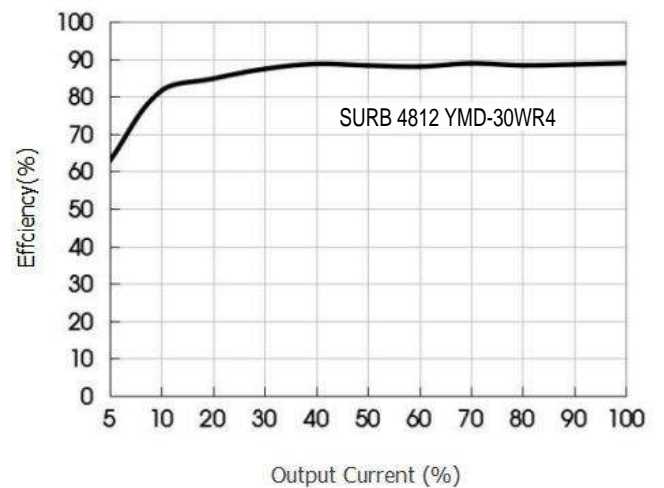

Typical Circuit Design And Application

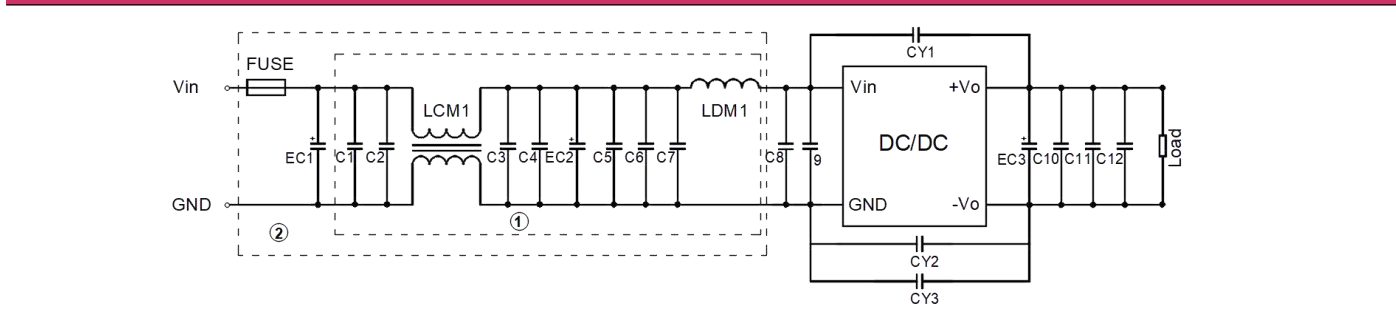
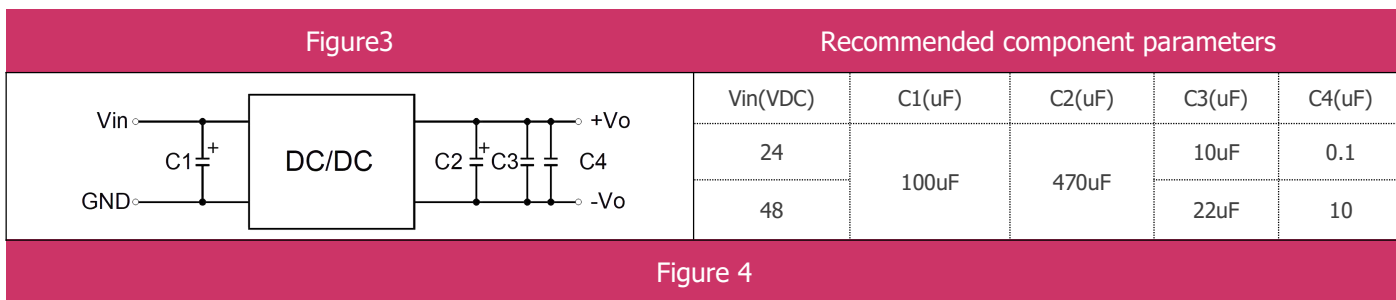

EMI Recommended component parameters

Vin (VDC)	24V	48V
FUSE	Choose according to actual input current	
CEC1	1000 (uF)	680 (uF)
EC2	220 (uF)	100 (uF)
C1,C2,C3,C4,C5,C6,C7	4.7 (uF)	4.7 (uF)
LCM1	0.32 (mH)	10 (mH)
LDM1	2.2 (uH)	6.8 (uH)
C8,C9	--	4 (uF)
CY2	222 (pF)	102 (pF)
CY1,CY3	2200 (pF)	2200 (pF)
EC3	470 (uF)	470 (uF)
C10	10 (uF)	22 (uF)
C11, C12	1 (uF)	10 (uF)

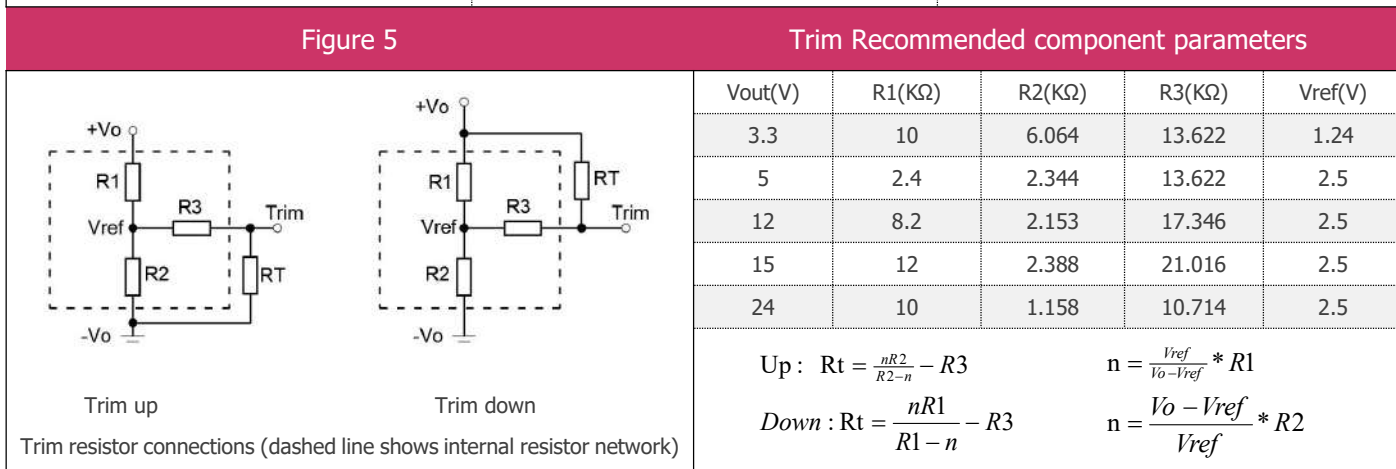

All DC-DC converters of this series are tested before delivery using the recommended circuit shown in Fig. 2. Input and/or output ripple can be further reduced by appropriately increasing the input & output capacitor values C_{in} and C_{out} and/or by selecting capacitors with a low ESR (equivalent series resistance). Also make sure that the capacitance is not exceeding the specified max. capacitive load value of the product.

SURA SURB YMD-30WR4

Dimensions and Recommended Layout

Dimensions

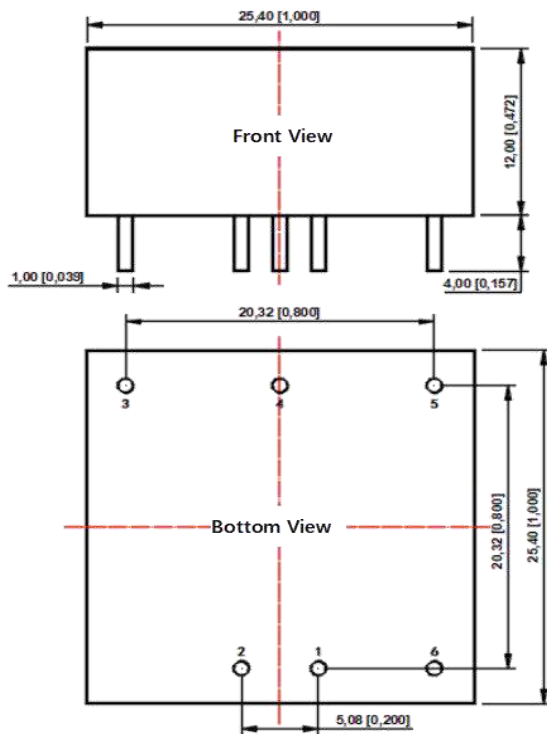

Note:

Unit: mm[inch]

Pin section tolerances: ± 0.10 [± 0.004]

General tolerances: ± 0.50 [± 0.020]

PCB Printing Layout

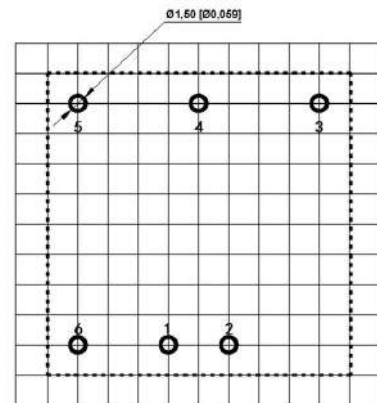

The grid distance is 2.54 x 2.54mm

Pin Definition Table

Pin	single	double
1	GND	GND
2	Vin	Vin
3	+Vo	+Vo
4	Trim	COM
5	-Vo	-Vo
6	Ctrl	Ctrl

Heatsink Dimensions

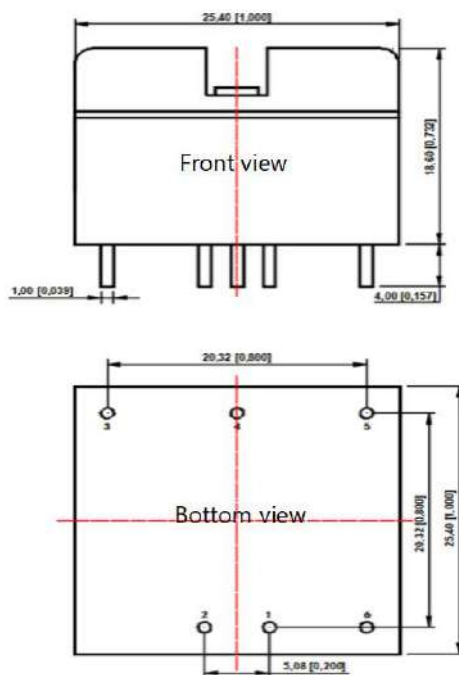

Note:

Unit: mm[inch]

Pin section tolerances: ± 0.10 [± 0.004]

General tolerances: ± 0.50 [± 0.020]

PCB Printing Layout

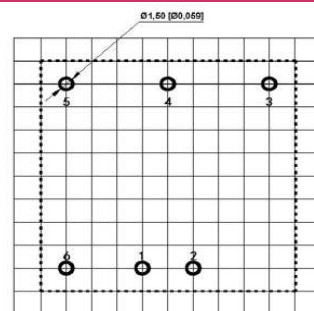

The grid distance is 2.54 x 2.54mm

Pin Definition Table

Pin	single	double
1	GND	GND
2	Vin	Vin
3	+Vo	+Vo
4	Trim	COM
5	-Vo	-Vo
6	Ctrl	Ctrl

A2S Dimensions

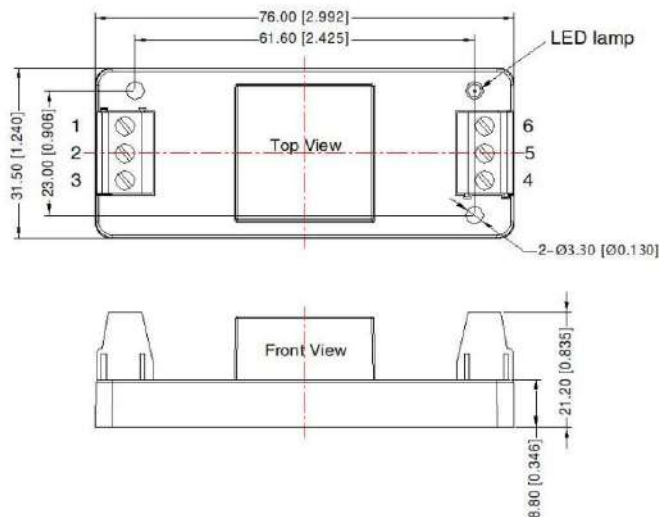

Pin Definition Table

Pin	single	double
1	Ctrl	Ctrl
2	GND	GND
3	Vin	Vin
4	+Vo	+Vo
5	Trim	COM
6	-Vo	-Vo

Note:

Unit: mm[inch]
 Wire range: 24-12 AWG
 Tightening torque: Max 0.4 N · m
 General tolerances: ± 1.00[±0.039]

A4S Dimensions

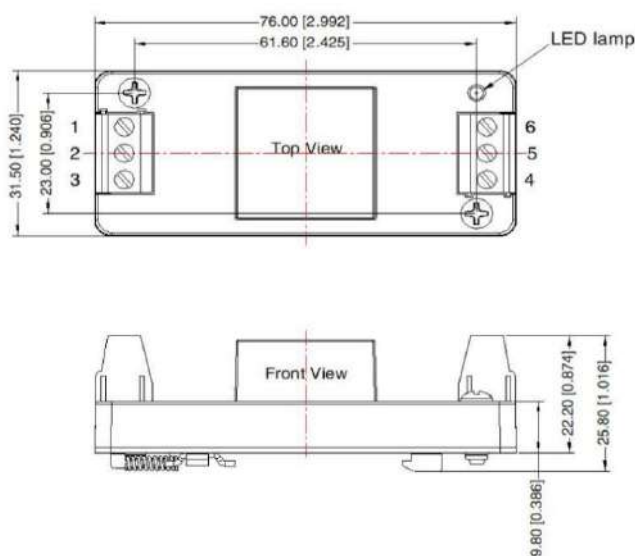

Pin Definition Table

Pin	single	double
1	Ctrl	Ctrl
2	GND	GND
3	Vin	Vin
4	+Vo	+Vo
5	Trim	COM
6	-Vo	-Vo

Note:

Unit: mm[inch]
 Mounting rail: TS35
 Wire range: 24-12 AWG
 Tightening torque: Max 0.4 N · m
 General tolerances: ± 1.00[±0.039]

Note:

- ❖ The input voltage should not exceed the specified range value, otherwise it may cause permanent and irreparable damage;
- ❖ It is recommended to use at a load of over 5%. If the load is below 5%, the ripple index of the product may exceed the specifications, but it does not affect the reliability of the product;
- ❖ The maximum capacitive load is tested within the input voltage range and under full load conditions;
- ❖ Unless otherwise specified, all indicators in this manual are measured at Ta=25 °C, humidity<75% RH, nominal input voltage, and output rated load;
- ❖ All indicator testing methods in this manual are based on our company's corporate standards;
- ❖ Our company can provide product customization, and specific requirements can be directly contacted by our technical personnel;
- ❖ Product specifications are subject to change without prior notice.