

# SURF 1Dxx LD-40WR5



## Product Feature

- ◆ Ultra-wide 4:1 Input voltage range
- ◆ Operating ambient temperature range: -40°C - +85°C
- ◆ Isolation voltage: 3000VDC/1500VAC
- ◆ High efficiency: 89% (Typ.)
- ◆ Output short-circuit protection, over-current protection, and over-voltage protection mechanisms.
- ◆ Application areas: Industry, Power, Instrumentation, Communication, Rail transit.



## Selection Guide

Part No. <sup>①</sup>	Input Voltage (VDC)		Output		Full Load Efficiency <sup>③</sup> (%) Typ.	Capacitive Load (μF) Max.
	Nominal <sup>②</sup> (Range)	Max. <sup>③</sup>	Voltage (VDC)	Current (mA) Max.		
SURF 1D03 LD-40WR5	110 (40-160)	170	3.3	10000	84	10000
SURF 1D05 LD-40WR5			5	8000	87	10000
SURF 1D12 LD-40WR5			12	3333	87	2700
SURF 1D15 LD-40WR5			15	2667	87	1680
SURF 1D24 LD-40WR5			24	1667	89	680

Note:

- ①. Suffix plus "H" means plus heat sink package, plus "A2S" for extended wiring package, suffix plus "A4S" for extended rail type package;
- ②. The "A2S" and "A4S" Model's start-up and minimum input voltages are increased by 1VDC due to the input reverse polarity protection circuit;
- ③. Absolute maximum stress rating without damage (not recommended);
- ④. Efficiency is measured at nominal input voltage and rated output load; efficiencies for "A2S" and "A4S" Model's is decreased by 2% due to the input reverse polarity protection circuit.

# SURF 1Dxx LD-40WR5



## Input Specifications

Item	Operating Conditions		Min.	Typ.	Max.	Unit
Input Current (Full Load/No-Load)	Nominal input series, nominal input voltage	3.3V Output	--	357/5	366/10	mA
		Others Output	--	418/5	429/10	
Reflected Ripple Current	Nominal input voltage		--	25	--	
Surge Voltage (1sec. max.)			-0.7	--	180	
Start-Up Voltage	100% load		--	--	40	VDC
Input Under-Voltage Protection			28	32	--	
Start Time	Nominal input and constant resistance load		--	20	--	ms
Ctrl <sup>①</sup>	Turn on module		Ctrl pin open or pulled high (TTL2.7-12VDC)			
	Turn off module		Ctrl pin pulled low to GND (0-1.2VDC)			
Input Filter			PI filter			
Hot Plug			Unavailable			
Note:						
①.The Ctrl pin voltage is referenced to input GND.						

## Output Specification

Item	Operating Conditions		Min.	Typ.	Max.	Unit
Output Voltage Accuracy	0%-100% load		--	±1.0	±3.0	
Linear Regulation	Vin=Min. to Max. @Full Load		--	±0.4	±1.0	%
Load Regulation	0%-100% load		--	±0.5	±1.0	
Ripple & Noise	20MHz bandwidth,100% load,parallel cable method		--	150	200	mVp-p
Transient Recovery Time	25% Load step change,nominal input voltage		--	300	500	μs
Transient Response Deviation	25% Load step change, nominal input voltage	3.3/5V output	--	±5.0	±8.0	%
		Others output	--	±3.0	±5.0	
Temperature Coefficient	Full load		--	±0.02	±0.03	%/°C
Trim			90	--	110	%Vo
Over-Voltage Protection			110	--	160	
Over-Current Protection	Input voltage range		110	140	--	%Io
Short-Circuit Protection			Continuous,Self-Recovery			

## General Specifications

Item	Operating Conditions	Min.	Typ.	Max.	Unit
Isolation Voltage	Input-output, test time 1 minute, leakage current less than 1mA	3000	--	--	VDC
	Input-output, test time 1 minute, leakage current less than 5mA	1500	--	--	VAC
	Input/output-case, test time 1 minute, leakage current less than 1mA	1500	--	--	VDC
Insulation Resistance	Input-output, resistance at 500VDC	1000	--	--	MΩ
Isolation Capacitance	Input-output, 100KHz/0.1V	--	2200	3000	pF
Operating Temperature	See Fig.1	-40	--	+85	°C
Storage Temperature		-55	--	+125	
Over-Temperature Protection		--	100	130	
Storage Humidity	Non-condensing	5	--	95	%RH
Soldering Profile	Wave-soldering	260±5°C; time:5 - 10s			
	Manual-welding	360±10°C;time:3 - 5s			
Switching Frequency	PWM	--	200	--	kHz
Vibration	IEC/EN 61373 -Category 1,Grade B				
MTBF	MIL-HDBK-217F@25°C	500	--	--	K hours

## Mechanical Specifications

Case Material	Aluminum alloy
Package Dimensions	50.80×25.40×11.80mm
Weight	28.5g (Typ.)
Cooling Method	Free air convection

## EMC Specifications

EMI	CE	CISPR32/EN55032 CLASS B (see Fig. 4-① for recommended circuit)			
	RE	CISPR32/EN55032 CLASS B (see Fig. 4-① for recommended circuit)			
EMS	ESD	IEC/EN61000-4-2	Contact ±6KV/Air ±8KV		Perf.Criteria B
	RS	IEC/EN61000-4-3	20V/m		Perf.Criteria A
	EFT	IEC/EN61000-4-4	100kHz ±4KV (see Fig. 4-② for recommended circuit)		Perf.Criteria B
	Surge	IEC/EN61000-4-5	line to line ±2KV (see Fig. 4-② for recommended circuit)		Perf.Criteria B
	CS	IEC/EN61000-4-6	10Vr.m.s		Perf.Criteria A

## Typical Characteristic Curves

Temperature Derating Curve (Fig. 1)

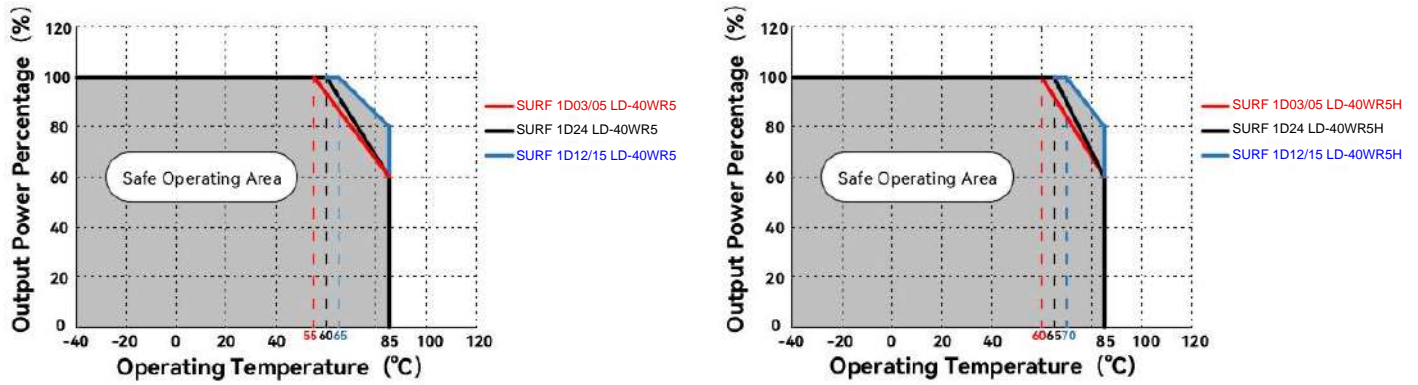

Input Voltage VS Output Power (Fig. 2)

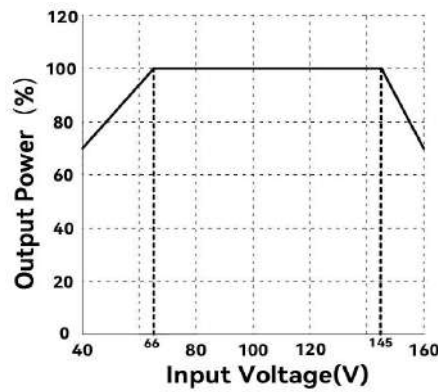

Note: Fig. 2 Input voltage VS output power derating curve for reference only, when operating, as long as the case temperature does not exceed 100°C, the product can be used under any conditions within the input voltage and output load range.

Efficiency VS Input Voltage (Full load)      Efficiency VS Output Load (Vin=110V)

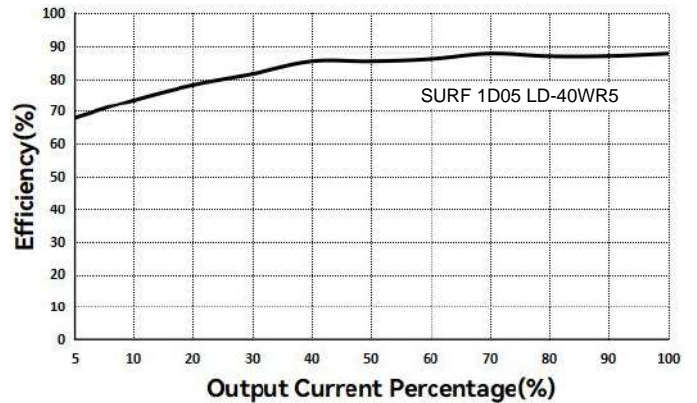
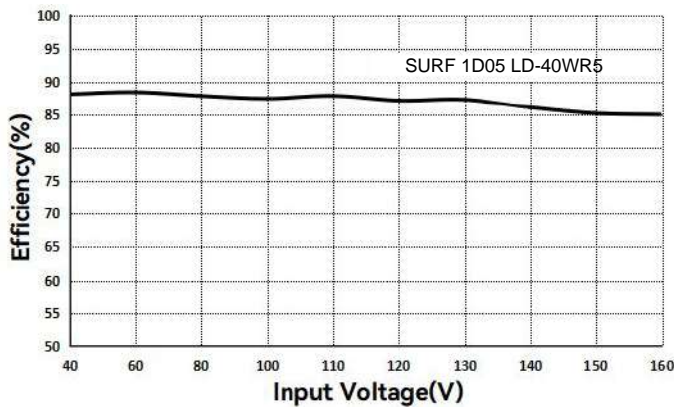

## Typical Circuit Design and Application

Recommended Circuit (Fig. 3)	Recommended Capacitive Load Value Table				
	Vout	C1	Co1	Co2	Co3
	3.3/5VDC	100µF/200V	470µF/16V	10µF/50V	0.1µF/16V
	12/15VDC	100µF/200V	220µF/25V	10µF/50V	0.1µF/25V
	24VDC	100µF/200V	100µF/50V	10µF/50V	0.1µF/50V

All the DC/DC converters of this series are tested before delivery using the recommended circuit shown in Fig. 3. Input and/or output ripple can be further reduced by appropriately increasing the input & output capacitor values C1 and Co1/Co2/Co3 and/or by selecting capacitors with a low ESR (equivalent series resistance). Also make sure that the capacitance is not exceeding the specified max. capacitive load value of the product.

EMC Recommended Circuit (Fig. 4)	EMC Recommended Parameter Table														
	<table border="1"> <tr> <td>Vout</td> <td>3.3V/5V/12V/15V/24V</td> </tr> <tr> <td>C0/C4</td> <td>100µF/200V</td> </tr> <tr> <td>C2/C3</td> <td>2.2µF/250V</td> </tr> <tr> <td>C1</td> <td>Refer to the C1 in Fig. 3</td> </tr> <tr> <td>LCM1</td> <td>10mH</td> </tr> <tr> <td>Co1/Co2/Co3</td> <td>Refer Fig. 3 capacitive load value table</td> </tr> <tr> <td>CY1/CY2</td> <td>2200pF/400VAC</td> </tr> </table>	Vout	3.3V/5V/12V/15V/24V	C0/C4	100µF/200V	C2/C3	2.2µF/250V	C1	Refer to the C1 in Fig. 3	LCM1	10mH	Co1/Co2/Co3	Refer Fig. 3 capacitive load value table	CY1/CY2	2200pF/400VAC
Vout	3.3V/5V/12V/15V/24V														
C0/C4	100µF/200V														
C2/C3	2.2µF/250V														
C1	Refer to the C1 in Fig. 3														
LCM1	10mH														
Co1/Co2/Co3	Refer Fig. 3 capacitive load value table														
CY1/CY2	2200pF/400VAC														
<p>Notes: For EMC tests we use Part ② in Fig. 4 for immunity and part ① for emissions test. Selecting based on needs.</p>															

Trim Recommended Circuit (Fig. 5)	Trim Recommended Component Parameters				
	Vout(V)	R1(KΩ)	R2(KΩ)	R3(KΩ)	Vref(V)
	3.3	10	6.064	13.622	1.24
	5	2.4	2.344	13.622	2.5
	12	8.2	2.153	17.346	2.5
	15	12	2.388	21.016	2.5
	24	10	1.158	10.714	2.5
<p>Trim resistor connections (dashed line shows internal resistor network)</p>	$\text{Up: } R_t = \frac{nR_2}{R_2 - n} - R_3$		$n = \frac{V_{ref}}{V_o - V_{ref}} * R_1$		
	$\text{Down: } R_t = \frac{nR_1}{R_1 - n} - R_3$		$n = \frac{V_o - V_{ref}}{V_{ref}} * R_2$		

# SURF 1Dxx LD-40WR5



## Dimensions and Recommended Layout

### Dimensions

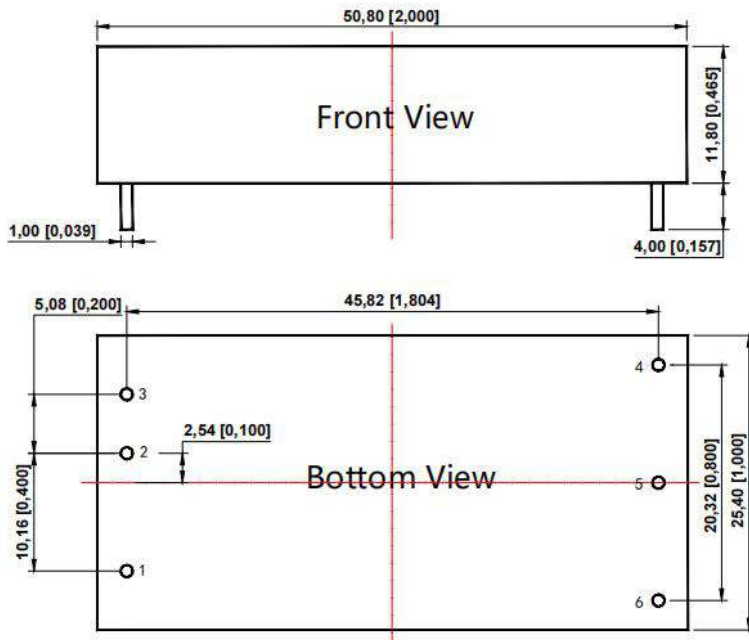

Note:

Unit: mm[inch]  
 Pin section tolerances:  $\pm 0.10[\pm 0.004]$   
 General tolerances:  $\pm 0.50[\pm 0.020]$

### PCB Printing Layout

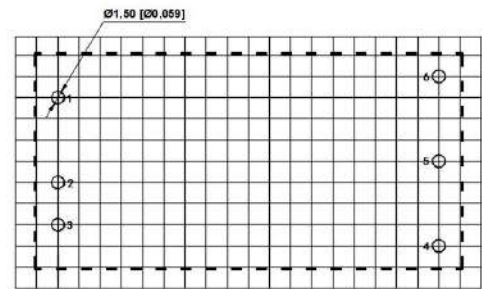

The grid distance is 2.54mm x 2.54mm

### Pin Definition Table

Pin	Single
1	Ctrl
2	GND
3	Vin
4	+Vo
5	-Vo
6	Trim

### H Dimensions

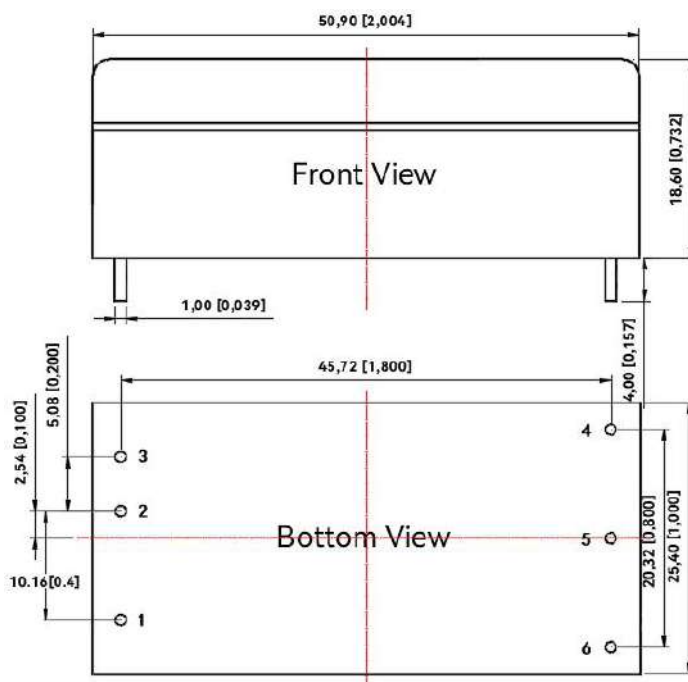

Note:

Unit: mm[inch]  
 Pin section tolerances:  $\pm 0.10[\pm 0.004]$   
 General tolerances:  $\pm 0.50[\pm 0.020]$

### PCB Printing Layout

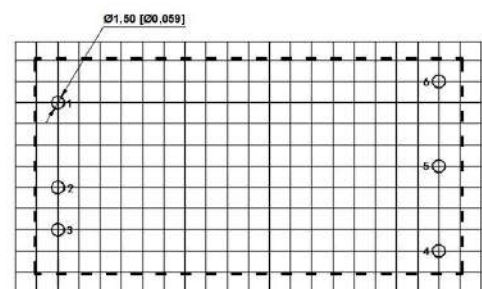

The grid distance is 2.54mm x 2.54mm

### Pin Definition Table

Pin	Single
1	Ctrl
2	GND
3	Vin
4	+Vo
5	-Vo
6	Trim

# SURF 1Dxx LD-40WR5



## A2S Dimensions

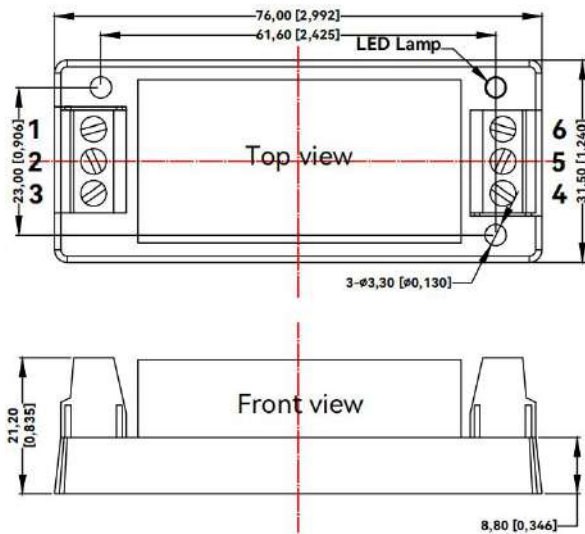

## Pin Definition Table

Pin	Single
1	Ctrl
2	GND
3	Vin
4	+Vo
5	-Vo
6	Trim

Note:

Unit: mm[inch]

Wire range: 24-12 AWG

General tolerances:  $\pm 1.00[\pm 0.039]$

Tightening torque: Max 0.4 N·m

## A4S Dimensions

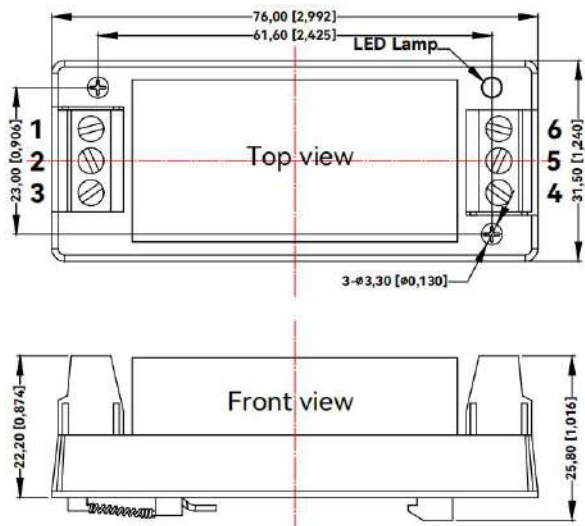

## Pin Definition Table

Pin	Single
1	Ctrl
2	GND
3	Vin
4	+Vo
5	-Vo
6	Trim

Note:

Unit: mm[inch]

Wire range: 24-12 AWG

General tolerances:  $\pm 1.00[\pm 0.039]$

Tightening torque: Max 0.4 N·m

## Packaging Instructions

### Packaging Information

Model series	Product quantity (pcs/pipe (tray) )	Inner carton quantity (pcs/ carton)	Outer carton quantity (pcs/ carton)
SURF 1Dxx LD-40WR5	19	228	912
SURF 1Dxx LD-40WR5H	19	228	912
SURF 1Dxx LD-40WR5 A2S	28	84	168
SURF 1Dxx LD-40WR5 A4S	28	84	168

# SURF 1Dxx LD-40WR5



## Note:

- ◇ The input voltage should not exceed the specified range value, otherwise it may cause permanent and irreparable damage;
- ◇ It is recommended to use at a load of over 5%. If the load is below 5%, the ripple index of the product may exceed the specifications, but it does not affect the reliability of the product;
- ◇ The maximum capacitive load is tested within the input voltage range and under full load conditions;
- ◇ Unless otherwise specified, all indicators in this manual are measured at  $T_a=25\text{ }^\circ\text{C}$ , humidity < 75% RH, nominal input voltage, and output rated load;
- ◇ All indicator testing methods in this manual are based on our company's corporate standards;
- ◇ Our company can provide product customization, and specific requirements can be directly contacted by our technical personnel;
- ◇ Product specifications are subject to change without prior notice.